

Fixed Universal Slip Clip

10 and 12 gauge fixed universal slip clip.

The clips are available in standard lengths of 6" and 8" in 12 and 10 gauge. They are ideal for medium to larger standoff conditions. FUS clips install quickly and provide adjustable standoff to ensure a plumb wall plane.

- Eliminates shims and scabs.
- Fast, one-piece universal installation. No left- or right-handed clips.
- Higher capacities when used in applications where significantly higher capacities are required.

PRODUCT DIMENSIONS

Lengths: 6" or 8"

MATERIAL SPECIFICATIONS

Gauge: 12 gauge (97mils)

Design Thickness: 0.1017 inches

Gauge: 10 gauge (118mils)

Design Thickness: 0.1242 inches

Coating: G90 (Z275 hot-dipped galvanized coating)

Material: Structural Grade 50 Type H (ST50H), 50ksi

ASTM: A653/A653M, ASTM A1003

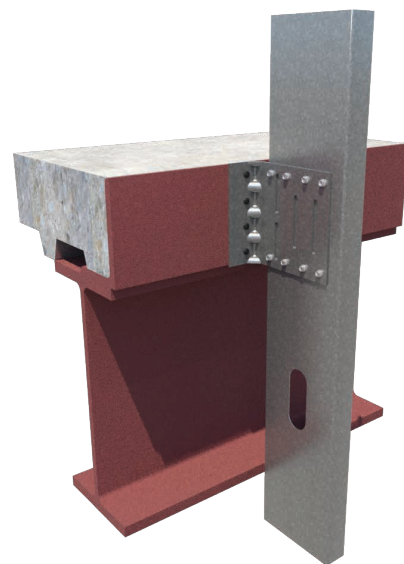
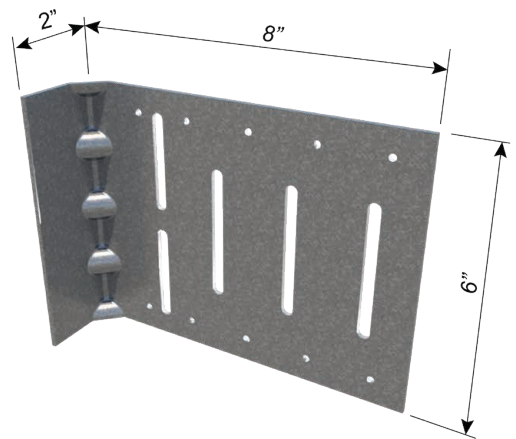
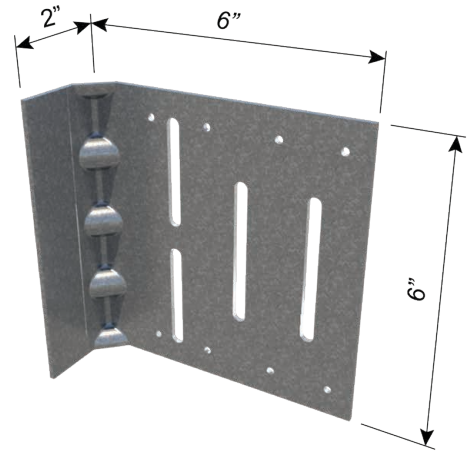

Fixed Universal Slip Clip (FUS6, FUS8)

Product code	Thickness		Clip length (in)	Packaging Pcs./Box
	Mils (Gauge)	Design thickness (in)		
FUS6-97	97mils (12ga)	0.1017	6	10
FUS8-97			8	10
FUS6-118	118mils (10ga)	0.1242	6	10
FUS8-118			8	10

U.S. Patent No. 11,905,700

INSTALLATION

Connections to the building can be made with screws, welds powder-actuated fasteners. Mechanical fasteners shall be located on the embossed marks given on the scored line of the 2" flange. Attach building anchors to the structure according to the manufacturer's instructions. Anchors shall be installed through the embossments on the scored line of the clip as shown on the attached drawings. In no case shall anchors be installed more than 3/4" from the bend on the short leg of the clip. In cases of discrepancy between this information and the Design Engineer's details, the Design Engineer's details shall be followed.

For a Rigid Connection:

Attach the FUS clip to cold-formed steel framing members using (8) #12 self-tapping screws (not included) for the FUS6 clip and (10) #12 self-drilling screws (not included) for the FUS8 clip through the clip holes into the steel framing. For a rigid connection, screws should not be installed in any of the slotted holes.

Fixed Universal Slip Clip Design Capacities					RIGID CONNECTIONS			
Product code	Clip thickness mils (gauge)	Clip length (in)	No. of #12 screws to framing	Stud thickness mils (gauge)	Capacities (lbs)			
					In-Plane	Tension	Compression	Shear
					F1	F2	F3	F4
FUS6-97	97mils (12ga)	6	8	33mils (20ga)	162	1550	1258	921
				43mils (18ga)	239	1974	1716	1555
				54mils (16ga)	323	2439	2217	2250
				68mils (14ga)	476	2468	2789	2402
				97mils (12ga)	793	2529	3971	2718
FUS8-97	97mils (12ga)	8	10	33mils (20ga)	162	1550	1258	921
				43mils (18ga)	250	1974	1652	1300
				54mils (16ga)	346	2439	2084	1716
				68mils (14ga)	513	2469	2638	2088
				97mils (12ga)	859	2531	3784	2857
FUS6-118	118mils (10ga)	6	8	33mils (20ga)	171	1538	1470	921
				43mils (18ga)	229	2358	2107	1555
				54mils (16ga)	294	3255	2805	2250
				68mils (14ga)	458	3286	3515	2402
				97mils (12ga)	799	3351	4982	2718
FUS8-118	118mils (10ga)	8	10	33mils (20ga)	171	1538	1470	921
				43mils (18ga)	241	2358	2216	1300
				54mils (16ga)	319	3255	3033	1716
				68mils (14ga)	474	3286	3672	2088
				97mils (12ga)	794	3351	4995	2857

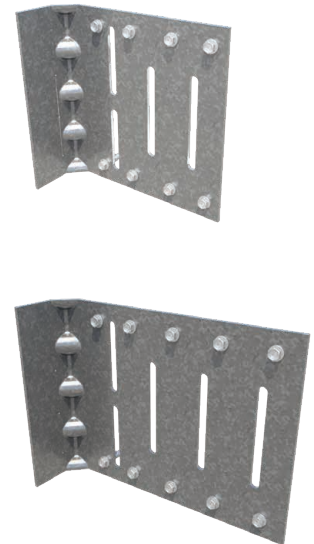

Notes:

- 1 Tabulated loads are based on testing with 600S162 CFS framing members.
- 2 Tabulated loads are based on single test conducted with two clips per test.
- 3 FUS was tested in compliance with ICC-ES AC-261 (2019) listed test setups.
- 4 #12 self-tapping screws were used to attach clips to framing members.
- 5 The ultimate screw shear strength and screw tension strength for #12 screws shall be at least 2000-lbs, and 2325-lbs respectively.
- 6 The screw strength capacities are based of CFSEI Tech Note (F701-12).
- 7 Allowable loads have not been increased for seismic or wind.